

2



LINES AND ANGLES



0674CH02

In this chapter, we will explore some of the most basic ideas of geometry including points, lines, rays, line segments and angles. These ideas form the building blocks of ‘plane geometry’, and will help us in understanding more advanced topics in geometry such as the construction and analysis of different shapes.

2.1 Point

Mark a dot on the paper with a sharp tip of a pencil. The sharper the tip, the thinner will be the dot. This tiny dot will give you an idea of a point. A point determines a precise location, but it has no length, breadth or height. Some models for a point are given below.

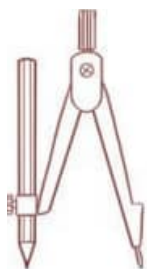

The tip of a compass



The sharpened end of a pencil



The pointed end of a needle

If you mark three points on a piece of paper, you may be required to distinguish these three points. For this purpose, each of the three points may be denoted by a single capital letter such as

Z

P

T

Z, P and T. These points are read as 'Point Z', 'Point P' and 'Point T'. Of course, the dots represent precise locations and must be imagined to be invisibly thin.

2.2 Line Segment

Fold a piece of paper and unfold it. Do you see a crease? This gives the idea of a line segment. It has two end points, A and B.

Mark any two points A and B on a sheet of paper. Try to connect A to B by various routes (Fig. 2.1).

What is the shortest route from A to B? This shortest path from Point A to Point B (including A and B) as shown here is called the **line segment** from A to B. It is denoted by either \overline{AB} or \overline{BA} . The points A and B are called the **end points** of the line segment \overline{AB} .

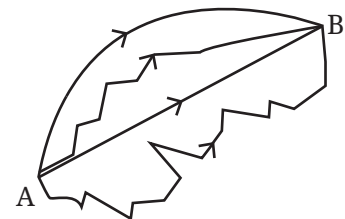
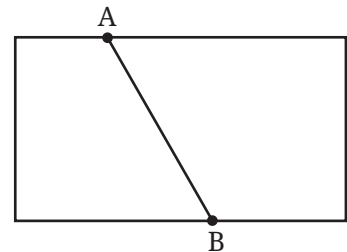

Fig. 2.1

2.3 Line

Imagine that the line segment from A to B (i.e., \overline{AB}) is extended beyond A in one direction and beyond B in the other direction without any end (see Fig. 2.2). This is a model for a **line**. Do you think you can draw a complete picture of a line? No. Why?

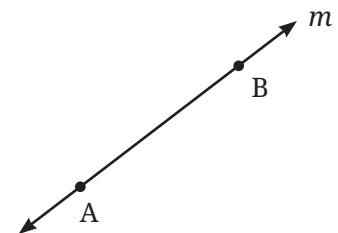

Fig. 2.2

A line through two points A and B is written as \overleftrightarrow{AB} . It extends forever in both directions. Sometimes a line is denoted by a letter like l or m .

Observe that any two points determine a unique line that passes through both of them.

2.4 Ray

A **ray** is a portion of a line that starts at one point (called the **starting point** or **initial point** of the ray) and goes on endlessly in a direction. The following are some models for a ray:



Beam of light from a lighthouse

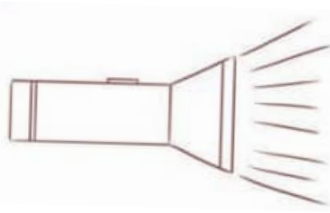

Ray of light from a torch

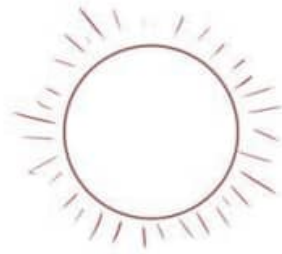

Sun rays

Look at the diagram (Fig. 2.3) of a ray. Two points are marked on it. One is the starting point A and the other is a point P on the path of the ray. We then denote the ray by \overrightarrow{AP} .

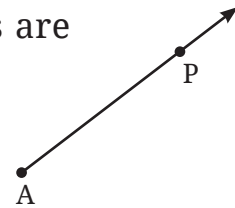

Fig. 2.3

Figure it Out

1.

Rihan marked a point on a piece of paper. How many lines can he draw that pass through the point?

Sheetal marked two points on a piece of paper. How many different lines can she draw that pass through both of the points?

Can you help Rihan and Sheetal find their answers?

2. Name the line segments in Fig. 2.4. Which of the five marked points are on exactly one of the line segments? Which are on two of the line segments?

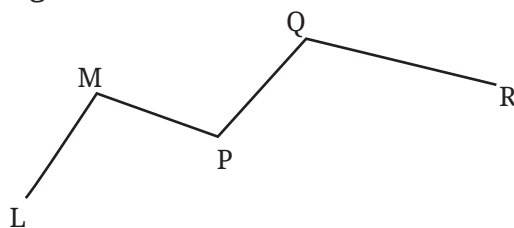

Fig. 2.4

3. Name the rays shown in Fig. 2.5. Is T the starting point of each of these rays?

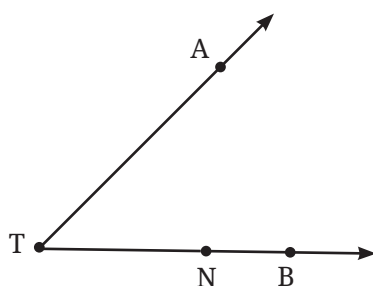

Fig. 2.5

4. Draw a rough figure and write labels appropriately to illustrate each of the following:

- \overleftrightarrow{OP} and \overleftrightarrow{OQ} meet at O.
- \overrightarrow{XY} and \overleftrightarrow{PQ} intersect at point M.
- Line l contains points E and F but not point D.
- Point P lies on AB.

5. In Fig. 2.6, name:

- Five points
- A line
- Four rays
- Five line segments

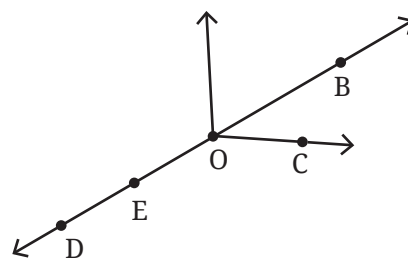

Fig. 2.6

6. Here is a ray \vec{OA} (Fig. 2.7). It starts at O and passes through the point A. It also passes through the point B.
- Can you also name it as \vec{OB} ? Why?
 - Can we write \vec{OA} as \vec{AO} ? Why or why not?

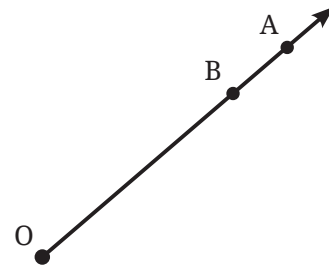

Fig. 2.7

2.5 Angle

An angle is formed by two rays having a common starting point. Here is an angle formed by rays \vec{BD} and \vec{BE} where B is the common starting point (Fig. 2.8).

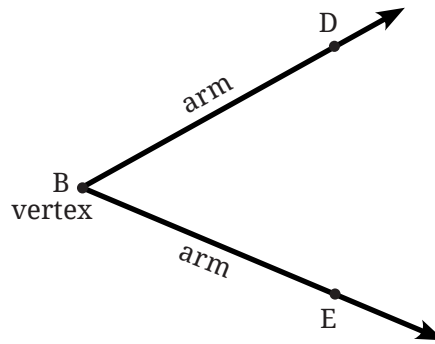
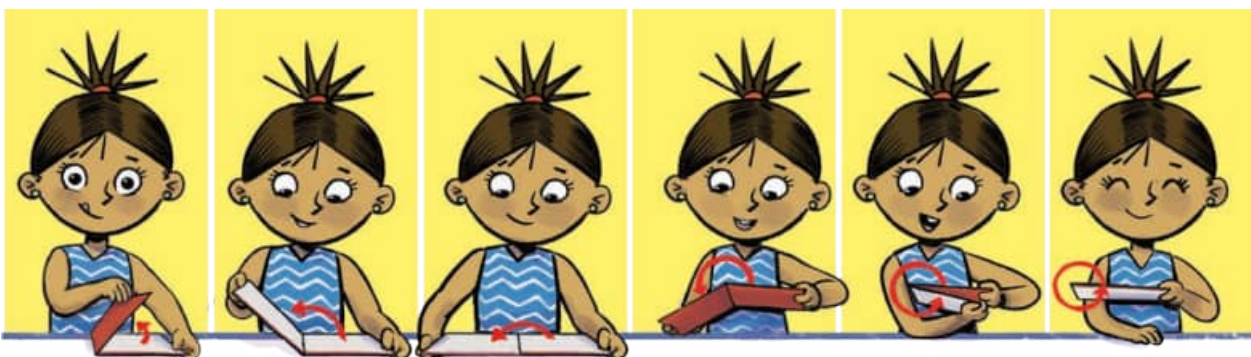

Fig. 2.8

The point B is called the **vertex** of the angle, and the rays \vec{BD} and \vec{BE} are called the **arms** of the angle. How can we name this angle? We can simply use the vertex and say that it is the Angle B. To be clearer, we use a point on each of the arms together with the vertex to name the angle. In this case, we name the angle as Angle DBE or Angle EBD. The word angle can be replaced by the symbol ' \angle ', i.e., $\angle DBE$ or $\angle EBD$. Note that in specifying the angle, the vertex is always written as the middle letter.

To indicate an angle, we use a small curve at the vertex (refer to Fig. 2.9).

Vidya has just opened her book. Let us observe her opening the cover of the book in different scenarios.



Case 1

Case 2

Case 3

Case 4

Case 5

Case 6

☀ Do you see angles being made in each of these cases? Can you mark their arms and vertex?

Which angle is greater—the angle in Case 1 or the angle in Case 2?

Just as we talk about the size of a line based on its length, we also talk about the size of an angle based on its amount of rotation.

So, the angle in Case 2 is greater as in this case she needs to rotate the cover more. Similarly, the angle in Case 3 is even larger than that of Case 2, because there is even more rotation, and Cases 4, 5, and 6 are successively larger angles with more and more rotation.

The size of an angle is the amount of rotation or turn that is needed about the vertex to move the first ray to the second ray.

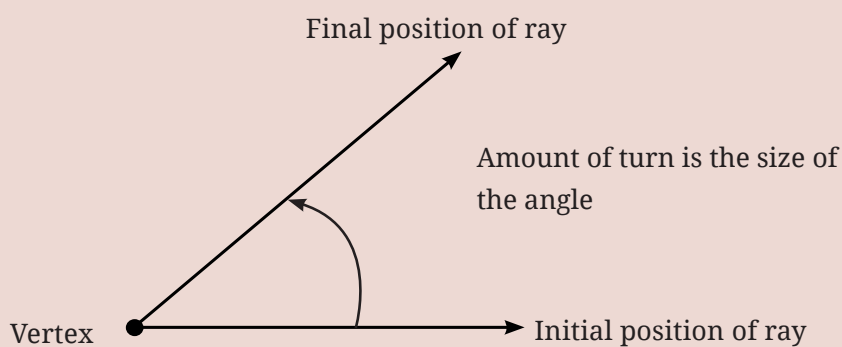

Fig. 2.9

Let's look at some other examples where angles arise in real life by rotation or turn:

- In a compass or divider, we turn the arms to form an angle. The vertex is the point where the two arms are joined. Identify the arms and vertex of the angle.
- A pair of scissors has two blades. When we open them (or 'turn them') to cut something, the blades form an angle. Identify the arms and the vertex of the angle.



- Look at the pictures of spectacles, wallet and other common objects. Identify the angles in them by marking out their arms and vertices.

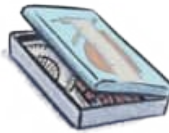

Do you see how these angles are formed by turning one arm with respect to the other?

Teacher's Note

Teacher needs to organise various activities with the students to recognise the size of an angle as a measure of rotation.

Figure it Out

1. Can you find the angles in the given pictures? Draw the rays forming any one of the angles and name the vertex of the angle.

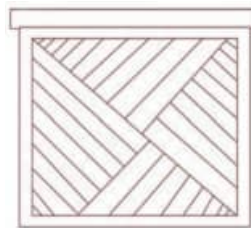
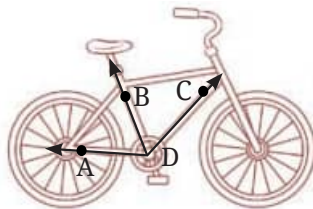



2. Draw and label an angle with arms ST and SR .
3. Explain why $\angle APC$ cannot be labelled as $\angle P$.

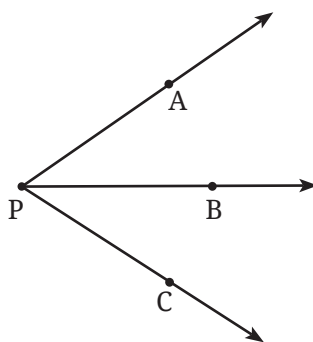

4. Name the angles marked in the given figure.

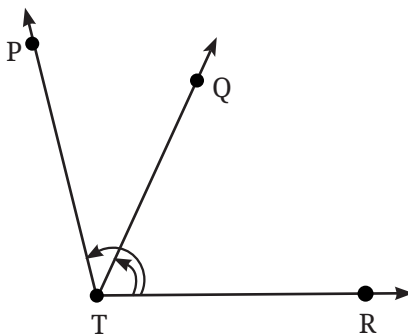

5. Mark any three points on your paper that are not on one line. Label them A, B, C. Draw all possible lines going through pairs of these points. How many lines do you get? Name them. How many angles can you name using A, B, C? Write them down, and mark each of them with a curve as in Fig. 2.9.

6. Now mark any four points on your paper so that no three of them are on one line. Label them A, B, C, D. Draw all possible lines going through pairs of these points. How many lines do you get? Name them. How many angles can you name using A, B, C, D? Write them all down, and mark each of them with a curve as in Fig. 2.9.

2.6 Comparing Angles

Look at these animals opening their mouths. Do you see any angles here? If yes, mark the arms and vertex of each one. Some mouths are open wider than others; the more the turning of the jaws, the larger the angle! Can you arrange the angles in this picture from smallest to largest?



 Is it always easy to compare two angles?

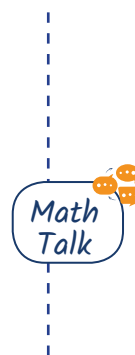
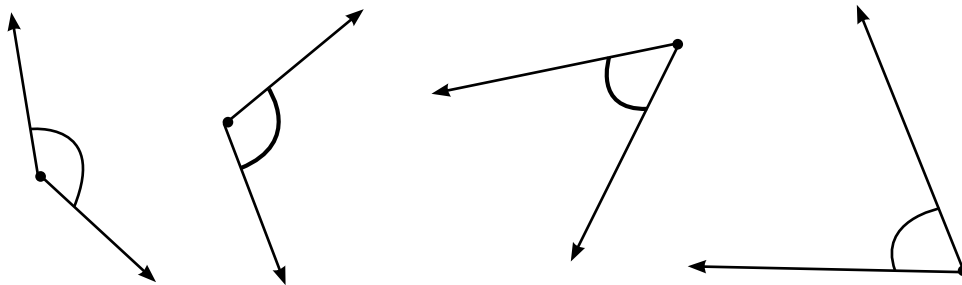

Here are some angles. Label each of the angles. How will you compare them?

Draw a few more angles; label them and compare.

Comparing angles by superimposition

Any two angles can be compared by placing them one over the other, i.e., by superimposition. While superimposing, the vertices of the angles must overlap.

After superimposition, it becomes clear which angle is smaller and which is larger.

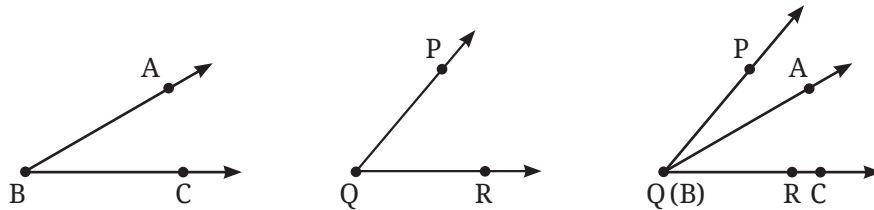

The picture shows the two angles superimposed. It is now clear that $\angle PQR$ is larger than $\angle ABC$.

Equal angles. Now consider $\angle AOB$ and $\angle XOY$ in the figure. Which is greater?

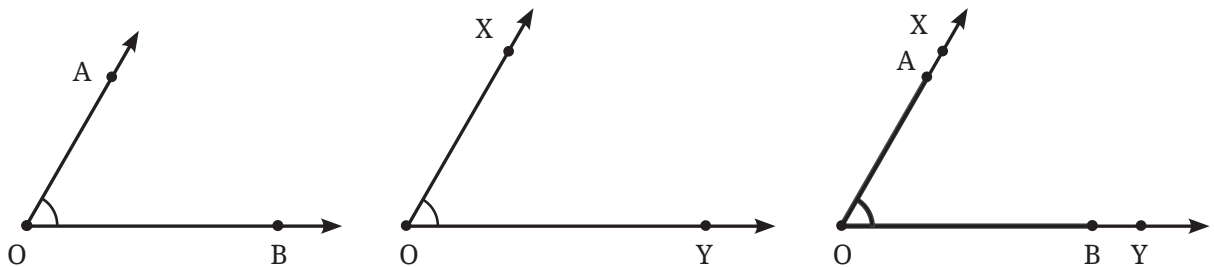

The corners of both of these angles match and the arms overlap with each other, i.e., $OA \leftrightarrow OX$ and $OB \leftrightarrow OY$. So, the angles are **equal** in size.

The reason these angles are considered to be equal in size is because when we visualise each of these angles as being formed out of rotation, we can see that there is an equal amount of rotation needed to move \overrightarrow{OB} to \overrightarrow{OA} and \overrightarrow{OY} to \overrightarrow{OX} .

From the point of view of superimposition, when two angles are superimposed, and the common vertex and the two rays of both angles lie on top of each other, then the sizes of the angles are equal.

☀ Where else do we use superimposition to compare?



☀ **Figure it Out**

1. Fold a rectangular sheet of paper, then draw a line along the fold created. Name and compare the angles formed between the fold and the sides of the paper. Make different angles by folding a rectangular sheet of paper and compare the angles. Which is the largest and smallest angle you made?



2. In each case, determine which angle is greater and why.

- a. $\angle AOB$ or $\angle XOY$
- b. $\angle AOB$ or $\angle XOB$
- c. $\angle XOB$ or $\angle XOC$

Discuss with your friends on how you decided which one is greater.

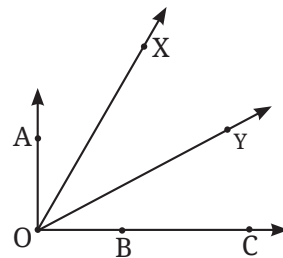

3. Which angle is greater: $\angle XOY$ or $\angle AOB$? Give reasons.

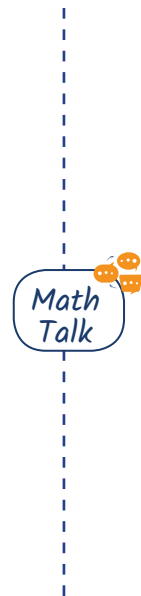
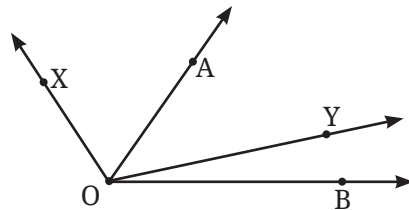

Comparing angles without superimposition

Two cranes are arguing about who can open their mouth wider, i.e., who is making a bigger angle.

Let us first draw their angles. How do we know which one is bigger? As seen

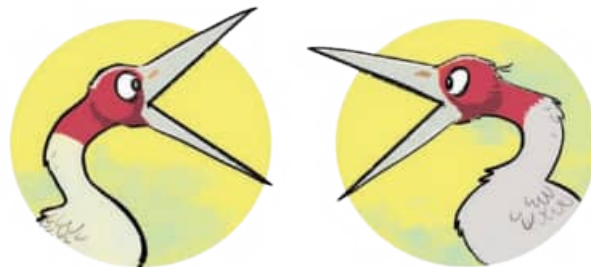
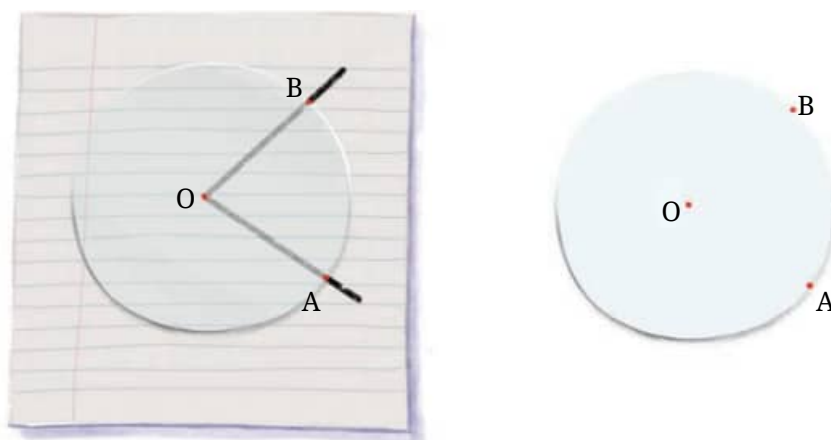

Fig. 2.10

before, one could trace these angles, superimpose them and then check. But can we do it without superimposition?

Suppose we have a transparent circle which can be moved and placed on figures. Can we use this for comparison?

Let us place the circular paper on the angle made by the first crane. The circle is placed in such a way that its centre is on the vertex of the angle. Let us mark the points A and B on the edge circle at the points where the arms of the angle pass through the circle.



Can we use this to find out if this angle is greater than, or equal to or smaller than the angle made by the second crane?

Let us place it on the angle made by the second crane so that the vertex coincides with the centre of the circle and one of the arms passes through OA.

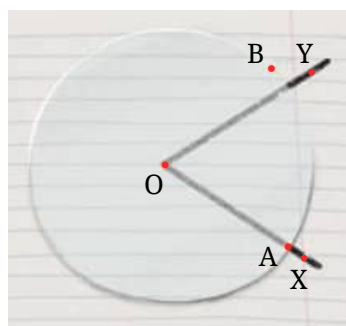

Can you now tell which angle is bigger?

Which crane was making the bigger angle?

If you can make a circular piece of transparent paper, try this method to compare the angles in Fig. 2.10 with each other.

Teacher's Note

A teacher needs to check the understanding of the students around the notion of an angle. Sometimes students might think that increasing the length of the arms of the angle increases the angle. For this, various situations should be posed to the students to check their understanding on the same.

2.7 Making Rotating Arms

Let us make 'rotating arms' using two paper straws and a paper clip by following these steps:

1. Take two paper straws and a paper clip.
2. Insert the straws into the arms of the paper clip.
3. Your rotating arm is ready!



Make several 'rotating arms' with different angles between the arms. Arrange the angles you have made from smallest to largest by comparing and using superimposition.

Passing through a slit: Collect a number of rotating arms with different angles; do not rotate any of the rotating arms during this activity.

Take a cardboard and make an angle-shaped slit as shown below by tracing and cutting out the shape of one of the rotating arms.

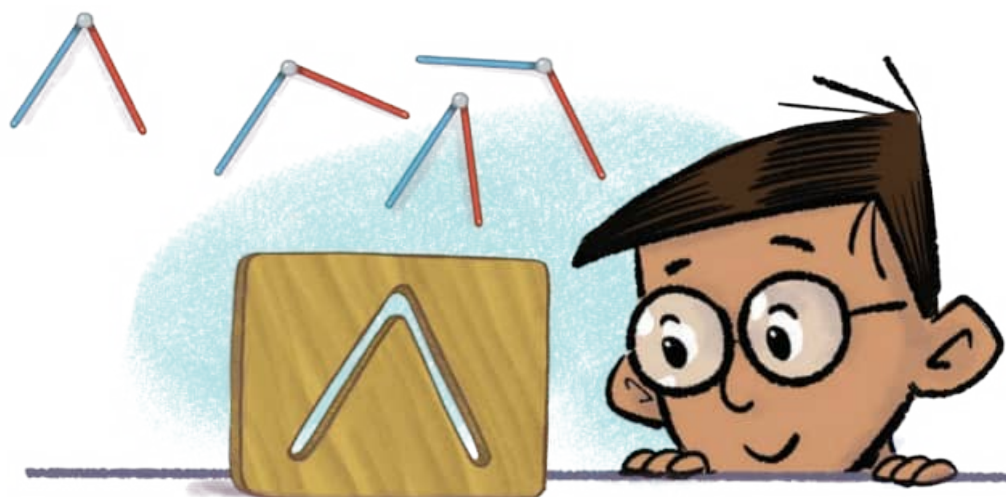

Now, shuffle and mix up all the rotating arms. Can you identify which of the rotating arms will pass through the slit?

The correct one can be found by placing each of the rotating arms over the slit. Let us do this for some of the rotating arms:



Slit angle is greater than the arms' angle. The arms will not go through the slit.

Slit angle is less than the arms' angle. The arms will not go through the slit.

Slit angle is equal to the arms' angle. The arms will go through the slit.

Only the pair of rotating arms where the angle is equal to that of the slit passes through the slit. Note that the possibility of passing through the slit depends only on the angle between the rotating arms and not on their lengths (as long as they are shorter than the length of the slit).

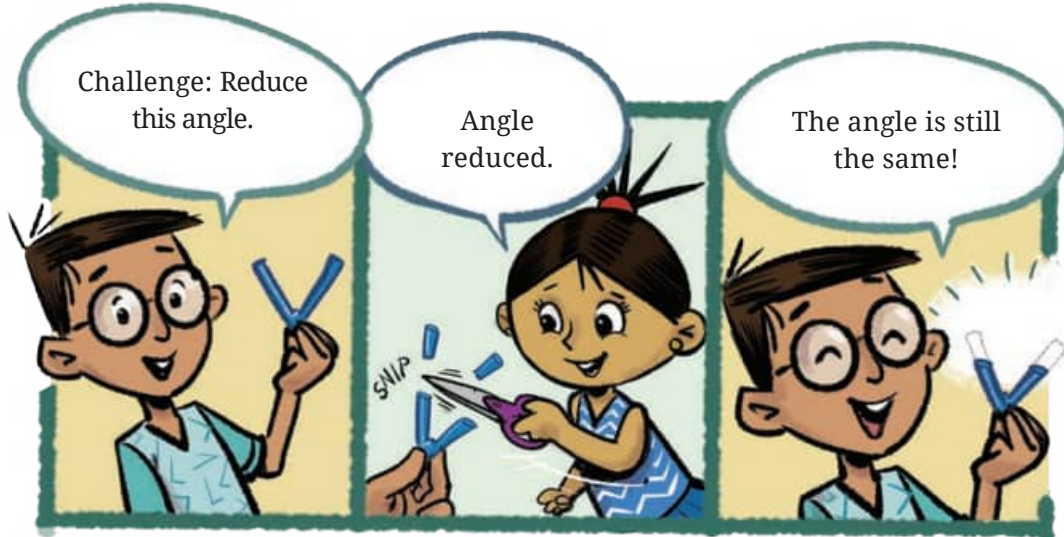

2.8 Special Types of Angles

Let us go back to Vidya's notebook and observe her opening the cover of the book in different scenarios.

She makes a full turn of the cover when she has to write while holding the book in her hand.

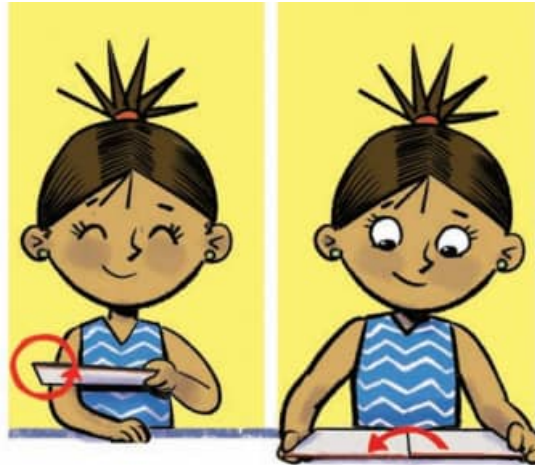

She makes a half turn of the cover when she has to open it on her table. In this case,

observe the arms of the angle formed. They lie in a straight line. Such an angle is called a **straight angle**.



Fig. 2.11

Let us consider a straight angle $\angle AOB$. Observe that any ray \vec{OC} divides it into two angles, $\angle AOC$ and $\angle COB$.

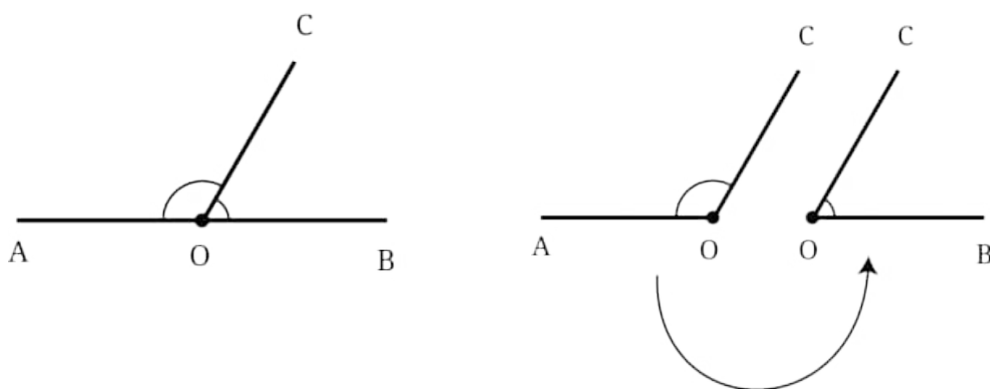

☀ Is it possible to draw \overrightarrow{OC} such that the two angles are equal to each other in size?



Let's Explore

We can try to solve this problem using a piece of paper. Recall that when a fold is made, it creates a crease which is straight.

Take a rectangular piece of paper and on one of its sides, mark the straight angle AOB . By folding, try to get a line (crease) passing through O that divides $\angle\text{AOB}$ into two equal angles.

How can it be done?

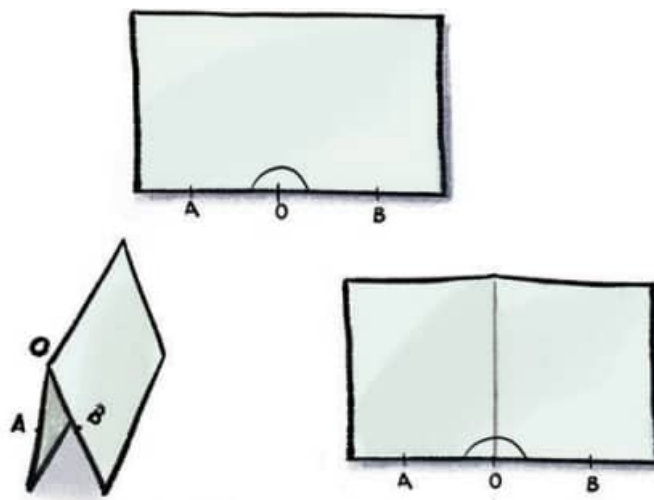

Fold the paper such that OB overlaps with OA. Observe the crease and the two angles formed.

Justify why the two angles are equal. Is there a way to superimpose and check? Can this superimposition be done by folding?

Each of these equal angles formed are called right angles. So, a straight angle contains two **right angles**.

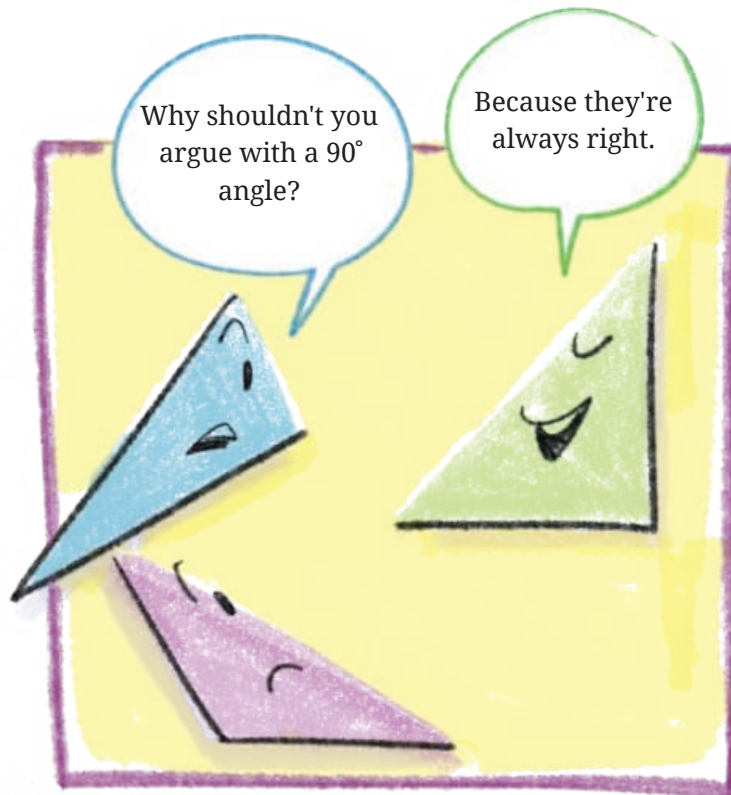

☀ If a straight angle is formed by half of a full turn, how much of a full turn will form a right angle?

Observe that a right angle resembles the shape of an 'L'. An angle is a right angle only if it is exactly half of a straight angle. Two lines that meet at right angles are called **perpendicular** lines.

☀ Figure it Out

1. How many right angles do the windows of your classroom contain? Do you see other right angles in your classroom?

2. Join A to other grid points in the figure by a straight line to get a straight angle. What are all the different ways of doing it?

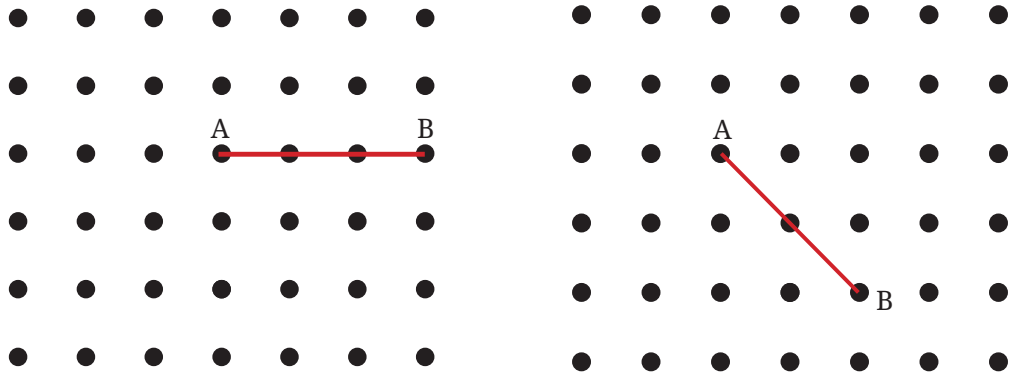

3. Now join A to other grid points in the figure by a straight line to get a right angle. What are all the different ways of doing it?

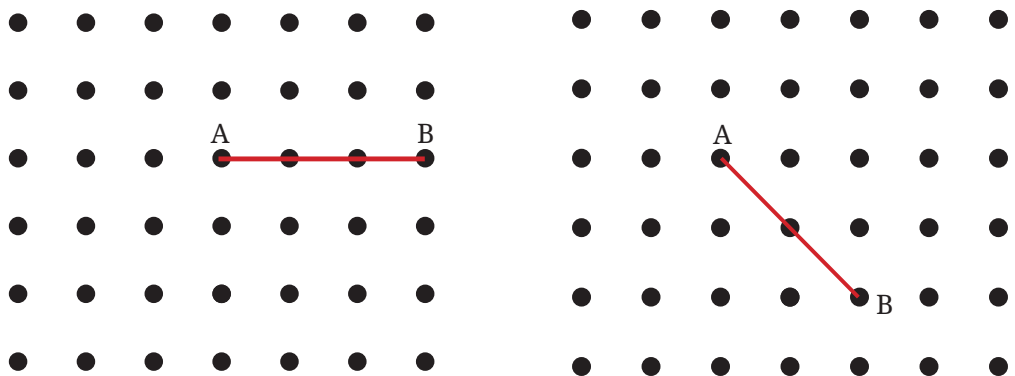

Hint: Extend the line further as shown in the figure below. To get a right angle at A, we need to draw a line through it that divides the straight angle CAB into two equal parts.

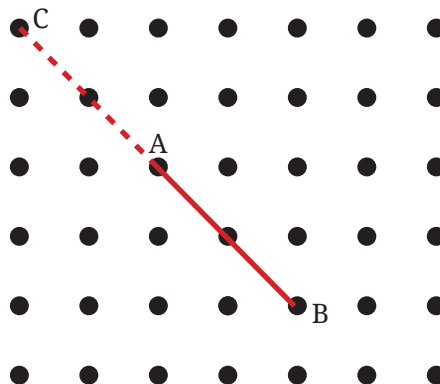

4. Get a slanting crease on the paper. Now, try to get another crease that is perpendicular to the slanting crease.
 - a. How many right angles do you have now? Justify why the angles are exact right angles.
 - b. Describe how you folded the paper so that any other person who doesn't know the process can simply follow your description to get the right angle.

Classifying Angles

Angles are classified in three groups as shown below. Right angles are shown in the second group. What could be the common feature of the other two groups?

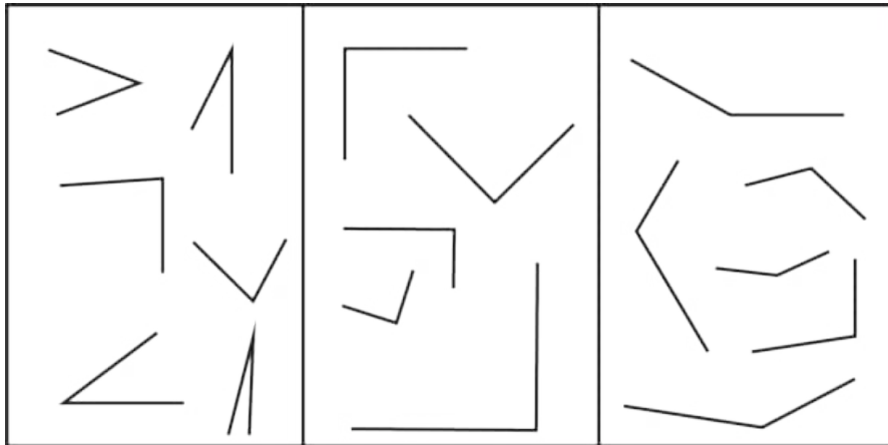

In the first group, all angles are less than a right angle or in other words, less than a quarter turn. Such angles are called **acute angles**.

In the third group, all angles are greater than a right angle but less than a straight angle. The turning is more than a quarter turn and less than a half turn. Such angles are called **obtuse angles**.

Figure it Out

1. Identify acute, right, obtuse and straight angles in the previous figures.
2. Make a few acute angles and a few obtuse angles. Draw them in different orientations.

3. Do you know what the words acute and obtuse mean? Acute means sharp and obtuse means blunt. Why do you think these words have been chosen?
4. Find out the number of acute angles in each of the figures below.

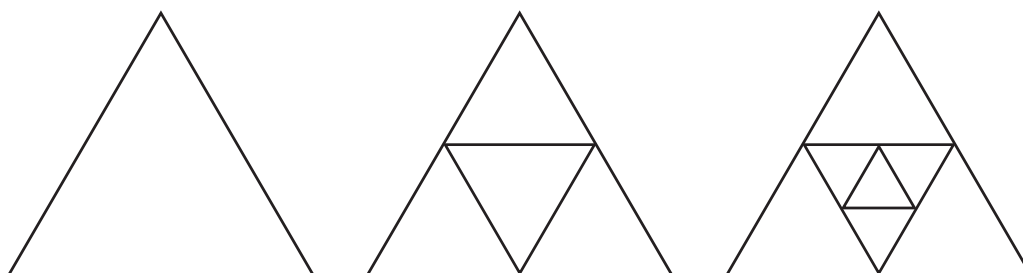

What will be the next figure and how many acute angles will it have? Do you notice any pattern in the numbers?

2.9 Measuring Angles

We have seen how to compare two angles. But can we actually quantify how big an angle is using a number without having to compare it to another angle?

We saw how various angles can be compared using a circle. Perhaps a circle could be used to assign measures for angles?

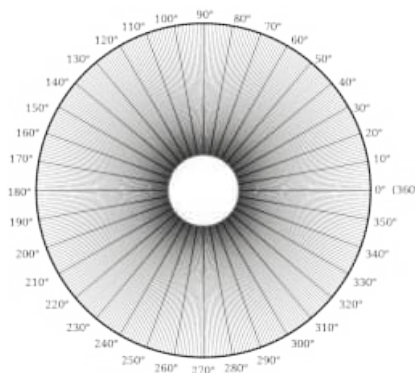
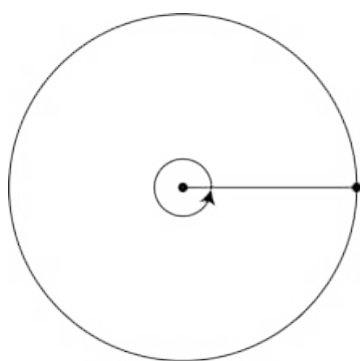
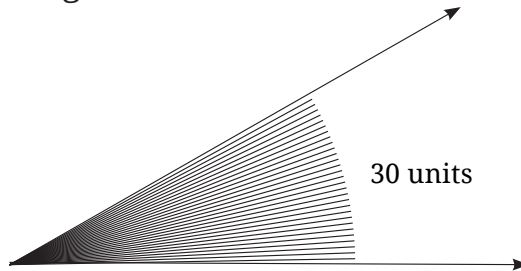

Fig. 2.12

To assign precise measures to angles, mathematicians came up with an idea. They divided the angle in the centre of the circle into

360 equal angles or parts. The angle measure of each of these unit parts is 1 degree, which is written as 1° .

This unit part is used to assign measure to any angle: the measure of an angle is the number of 1° unit parts it contains inside it. For example, see this figure:



It contains 30 units of 1° angle and so we say that its angle measure is 30° .

Measures of different angles: What is the measure of a full turn in degrees? As we have taken it to contain 360 degrees, its measure is 360° .

☀ What is the measure of a straight angle in degrees? A straight angle is half of a full turn. As a full-turn is 360° , a half turn is 180° .
 What is the measure of a right angle in degrees? Two right angles together form a straight angle. As a straight angle measures 180° , a right angle measures 90° .

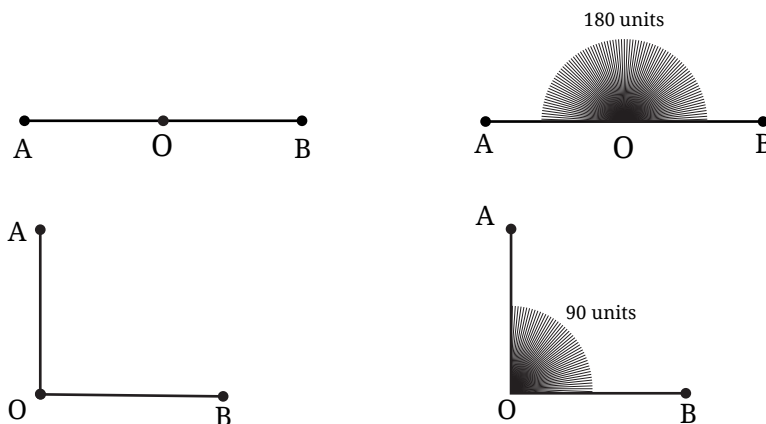

A pinch of history

A full turn has been divided into 360° . Why 360? The reason why we use 360° today is not fully known. The division of a circle into

360 parts goes back to ancient times. The *Rigveda*, one of the very oldest texts of humanity going back thousands of years, speaks of a wheel with 360 spokes (Verse 1.164.48). Many ancient calendars, also going back over 3000 years—such as calendars of India, Persia, Babylonia and Egypt—were based on having 360 days in a year. In addition, Babylonian mathematicians frequently used divisions of 60 and 360 due to their use of sexagesimal numbers and counting by 60s.

Perhaps the most important and practical answer for why mathematicians over the years have liked and continued to use 360 degrees is that 360 is the smallest number that can be evenly divided by all numbers up to 10, aside from 7. Thus, one can break up the circle into 1, 2, 3, 4, 5, 6, 8, 9 or 10 equal parts, and still have a whole number of degrees in each part! Note that 360 is also evenly divisible by 12, the number of months in a year, and by 24, the number of hours in a day. These facts all make the number 360 very useful.

☀ The circle has been divided into 1, 2, 3, 4, 5, 6, 8, 9, 10 and 12 parts below. What are the degree measures of the resulting angles? Write the degree measures down near the indicated angles.

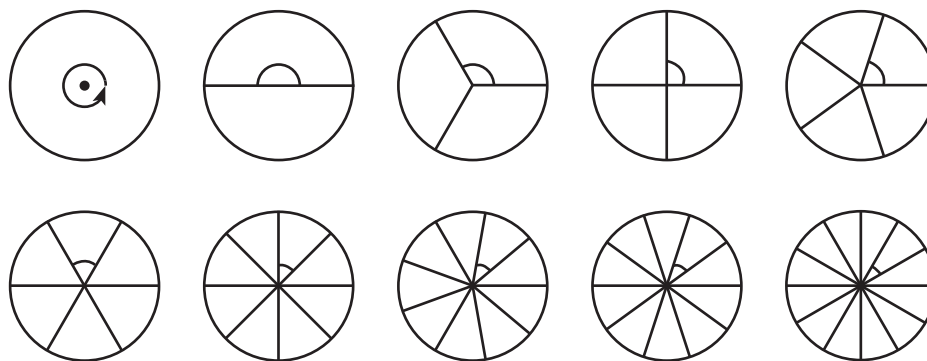

Degree measures of different angles

How can we measure other angles in degrees? It is for this purpose that we have a tool called a **protractor** that is either a circle divided into 360 equal parts as shown in Fig. 2.12 (on page 32), or a half circle divided into 180 equal parts.

Unlabelled protractor

Here is a protractor. Do you see the straight angle at the center divided into 180 units of 1 degree? Only part of the lines dividing the straight angle are visible, though!

Starting from the marking on the rightmost point of the base, there is a long mark for every 10° . From every such long mark, there is a medium sized mark after 5° .

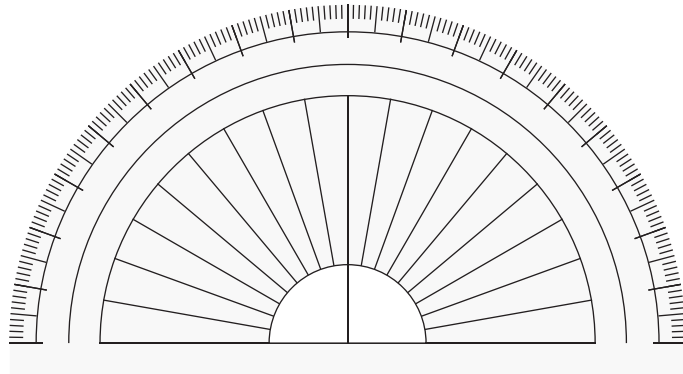
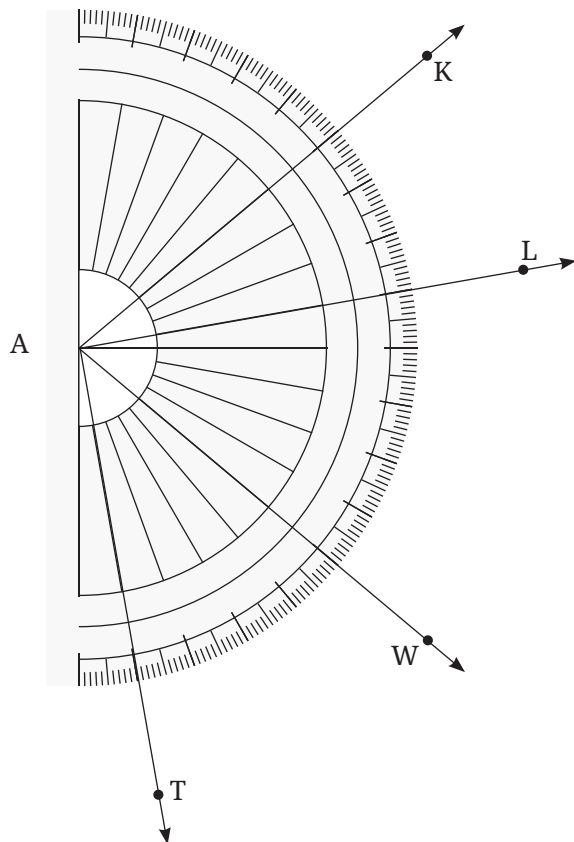

Figure it out



1. Write the measures of the following angles:

a. $\angle KAL$

Notice that the vertex of this angle coincides with the centre of the protractor. So the number of units of 1 degree angle between KA and AL gives the measure of $\angle KAL$. By counting, we get —

$$\angle KAL = 30^\circ$$

Making use of the medium sized and large sized marks, is it possible to count the number of units in 5s or 10s?

b. $\angle WAL$

c. $\angle TAK$

Labelled protractor

This is a protractor that you find in your geometry box. It would appear similar to the protractor above except that there are numbers written on it. Will these make it easier to read the angles?

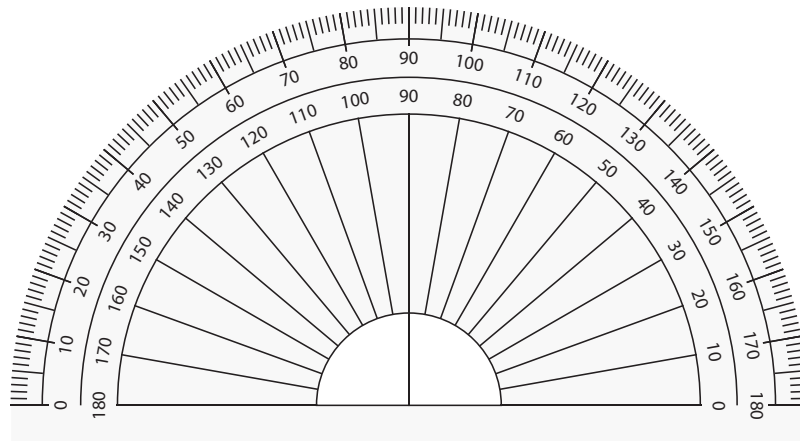

There are two sets of numbers on the protractor: one increasing from right to left and the other increasing from left to right. Why does it include two sets of numbers?

☀ Name the different angles in the figure and write their measures.

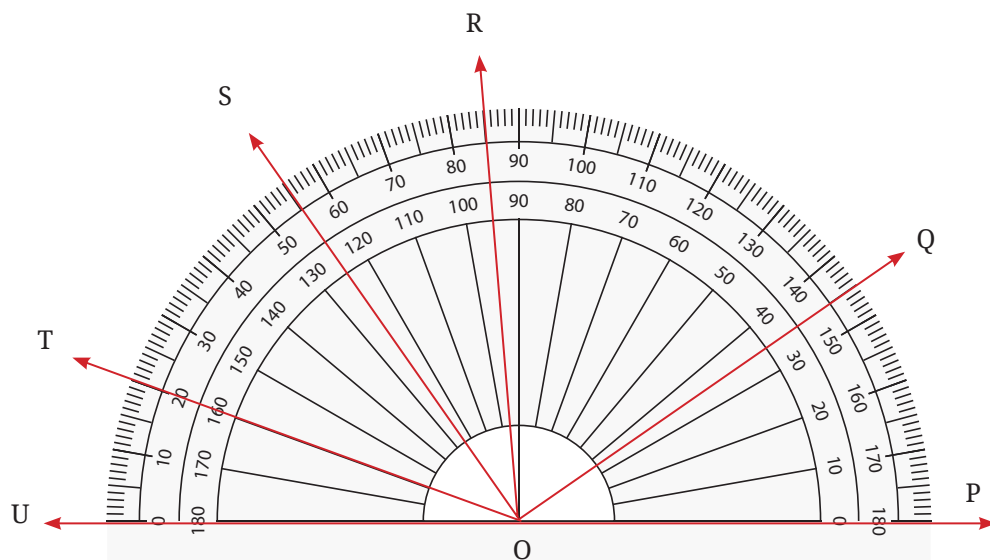

Did you include angles such as $\angle TOQ$?

Which set of markings did you use—inner or outer?

What is the measure of $\angle TOS$?

Can you use the numbers marked to find the angle without counting the number of markings?

Here, OT and OS pass through the numbers 20 and 55 on the outer scale. How many units of 1 degree are contained between these two arms?

Can subtraction be used here?

How can we measure angles directly without having to subtract?

Place the protractor so the center is on the vertex of the angle.

Align the protractor so that one of the arms passes through the 0° mark as in the picture below.

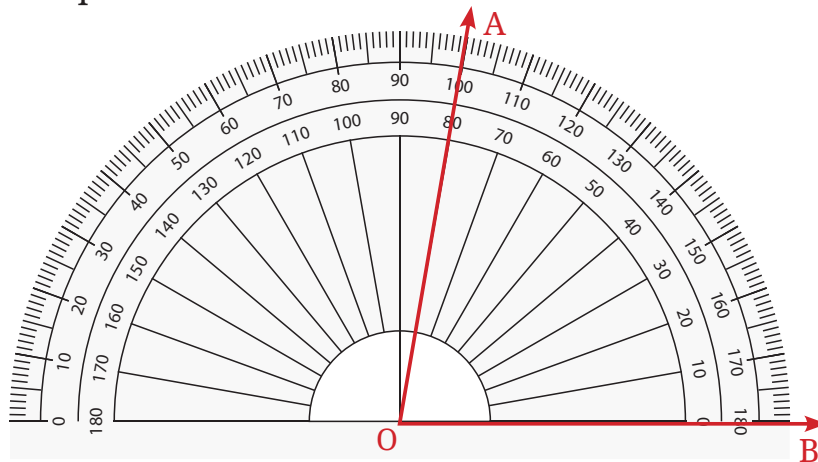

What is the degree measure of $\angle AOB$?

Make your own Protractor!

You may have wondered how the different equally spaced markings are made on a protractor. We will now see how we can make some of them!

1. Draw a circle of a convenient radius on a sheet of paper. Cut out the circle (Fig. 2.13). A circle or one full turn is 360° .
2. Fold the circle to get two equal halves and cut it through the crease to get a semicircle. Write '0°' in the bottom right corner of the semicircle.

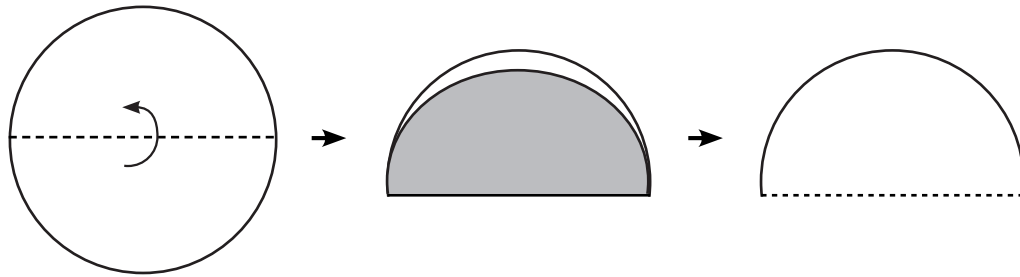

Fig. 2.13

<p>Fig. 2.14</p>	<p>The measure of half a circle is $\frac{1}{2}$ of a full turn. (Fig. 2.14)</p> <p>So, the measure of half a turn = $\frac{1}{2}$ of _____ = 180°.</p> <p>Thus, write 180° in the left bottom corner of the semicircle.</p>	
------------------	--	--

3. Fold the semi-circular sheet in half as shown in Fig. 2.15 to form a quarter circle.

<p>Fig. 2.15</p>	<p>The measure of a quarter circle is $\frac{1}{4}$ of a full turn.</p> <p>The measure of a $\frac{1}{4}$ turn = $\frac{1}{4}$ of 360° = _____.</p> <p>Or, the measure of a $\frac{1}{4}$ turn = $\frac{1}{2}$ of a half turn = $\frac{1}{2}$ of 180° = _____.</p> <p>Thus, mark 90° at the top of the semicircle.</p>	
------------------	--	--

4. Fold the sheet again as shown in Figs. 2.16 and 2.17:

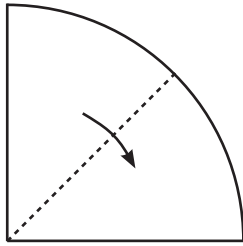

Fig. 2.16

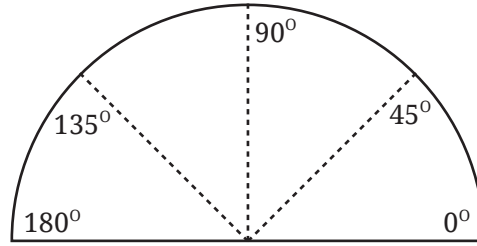

Fig. 2.17

When folded, this is $\frac{1}{8}$ of the circle, or $\frac{1}{8}$ of a turn, or $\frac{1}{8}$ of 360° , or $\frac{1}{4}$ of 180° or $\frac{1}{2}$ of $90^\circ =$ _____.

The new creases formed give us measures of 45° and $180^\circ - 45^\circ = 135^\circ$ as shown. Write 45° and 135° at the correct places on the new creases along the edge of the semicircle.

5. Continuing with another half fold as shown in Fig. 2.18, we get an angle of measure _____.

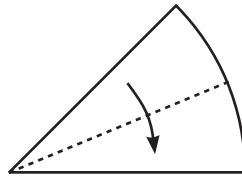

Fig. 2.18

6. Unfold and mark the creases as OB, OC, ..., etc., as shown in Fig. 2.19 and Fig. 2.20.

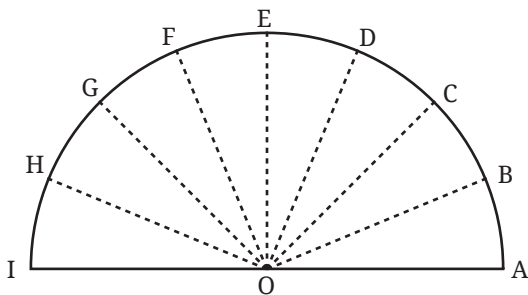

Fig. 2.19

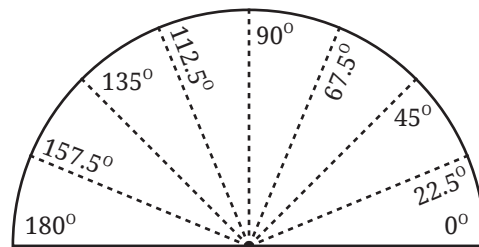

Fig. 2.20

☀ Think!

In Fig. 2.19, we have $\angle AOB = \angle BOC = \angle COD = \angle DOE = \angle EOF = \angle FOG = \angle GOH = \angle HOI = \underline{\hspace{2cm}}$. Why?

● Angle Bisector ●

At each step, we folded in halves. This process of getting half of a given angle is called **bisecting the angle**. The line that bisects a given angle is called the **angle bisector** of the angle.

Identify the angle bisectors in your handmade protractor. Try to make different angles using the concept of angle bisector through paper folding.

☀ Figure it Out

- Find the degree measures of the following angles using your protractor.

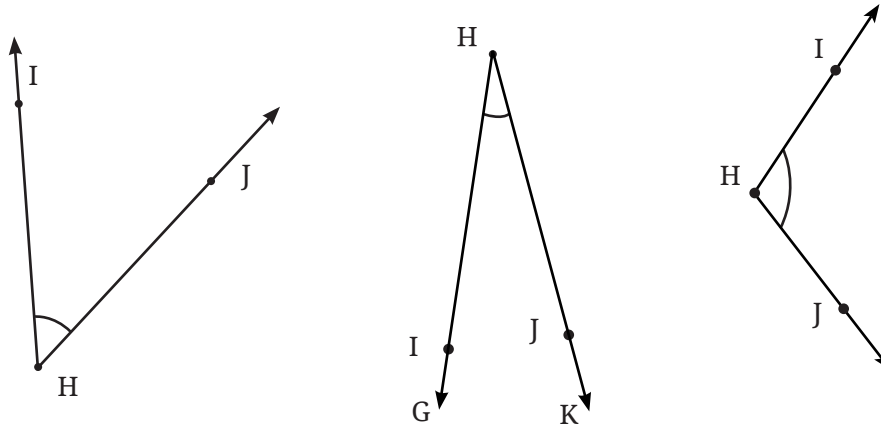

- Find the degree measures of different angles in your classroom using your protractor.

Teacher's Note

It is important that students make their own protractor and use it to measure different angles before using the standard protractor so that they know the concept behind the marking of the standard protractor.

3. Find the degree measures for the angles given below. Check if your paper protractor can be used here!

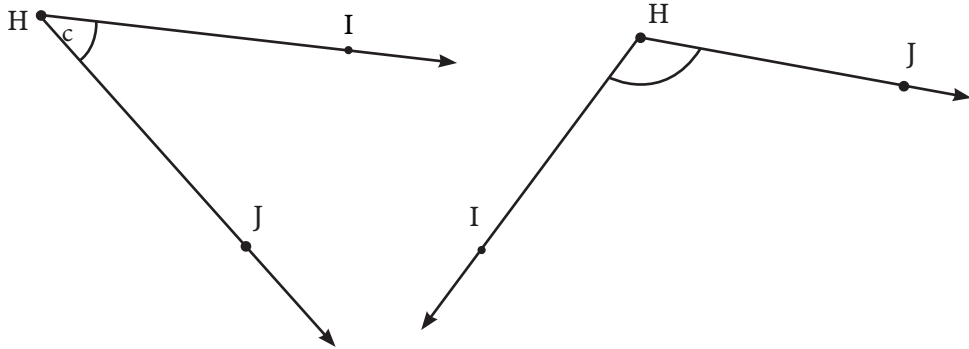

4. How can you find the degree measure of the angle given below using a protractor?

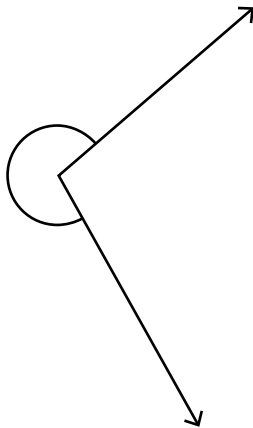

5. Measure and write the degree measures for each of the following angles:

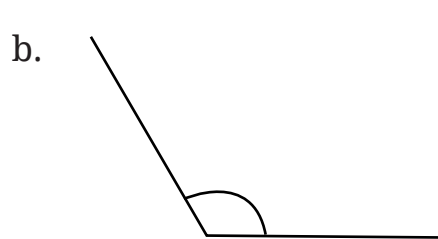
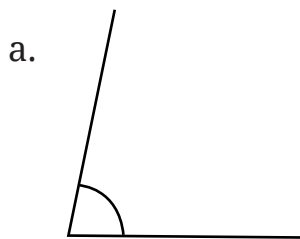

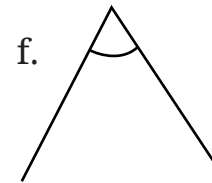
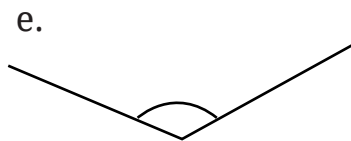
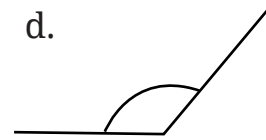
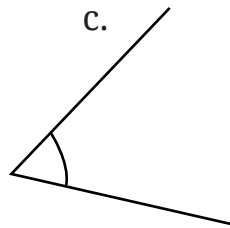

6. Find the degree measures of $\angle BXE$, $\angle CXE$, $\angle AXB$ and $\angle BXC$.

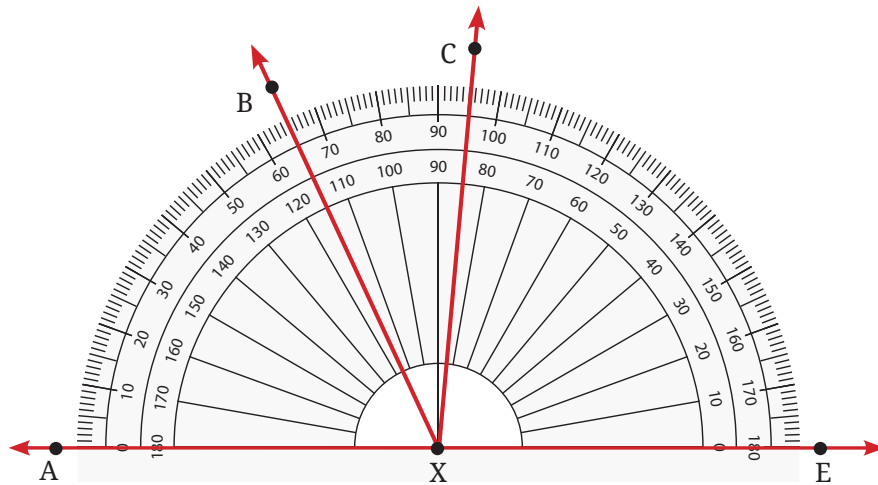

7. Find the degree measures of $\angle PQR$, $\angle PQS$ and $\angle PQT$.

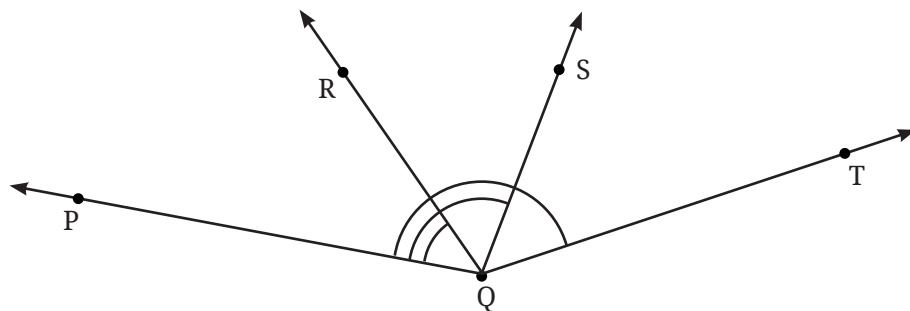

8. Make the paper craft as per the given instructions. Then, unfold and open the paper fully. Draw lines on the creases made and measure the angles formed.

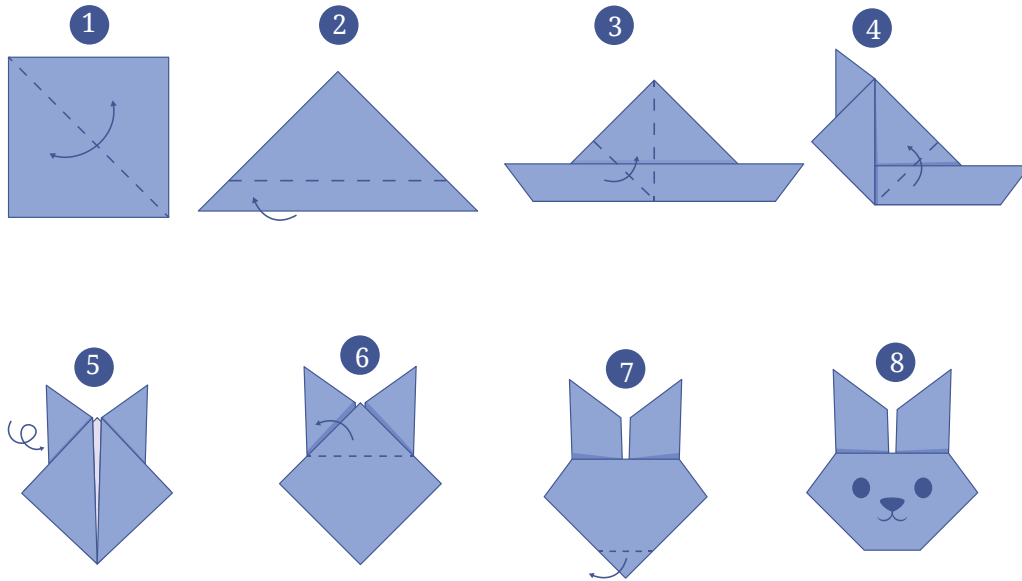

9. Measure all three angles of the triangle shown in Fig. 2.21 (a), and write the measures down near the respective angles. Now add up the three measures. What do you get? Do the same for the triangles in Fig. 2.21 (b) and (c). Try it for other triangles as well, and then make a conjecture for what happens in general! We will come back to why this happens in a later year.

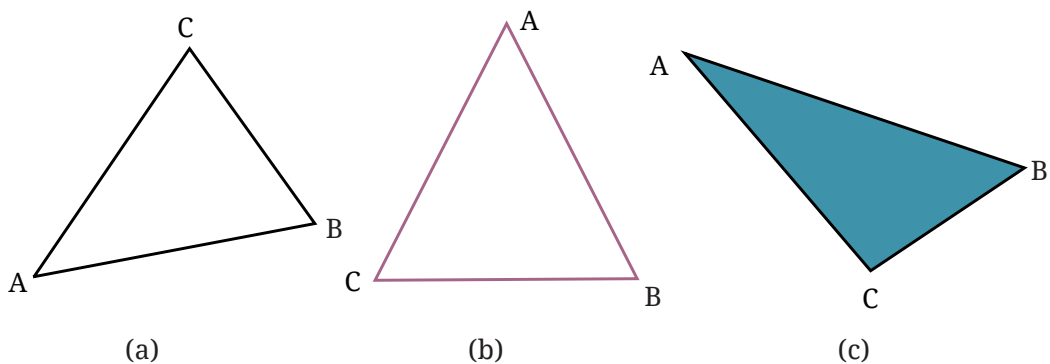
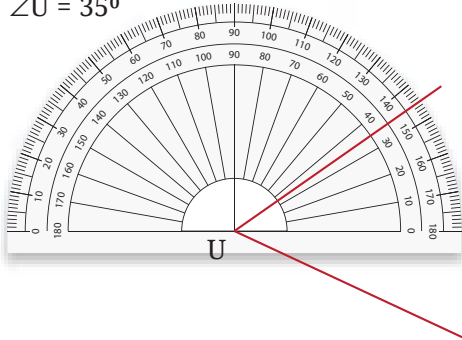

Fig. 2.21

Mind the Mistake, Mend the Mistake!

A student used a protractor to measure the angles as shown below. In each figure, identify the incorrect usage(s) of the protractor and discuss how the reading could have been made and think how it can be corrected.

$\angle U = 35^\circ$



$\angle V = 80^\circ$

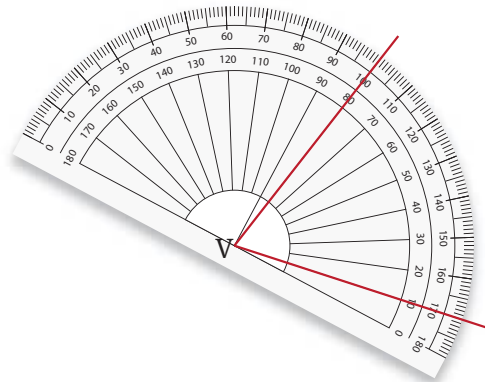

$\angle W = 70^\circ$

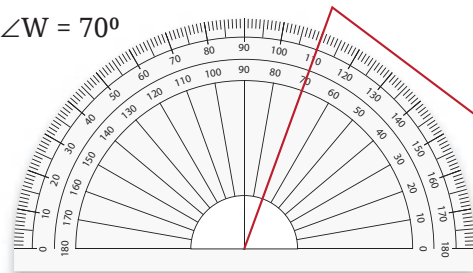

$\angle X = 150^\circ$

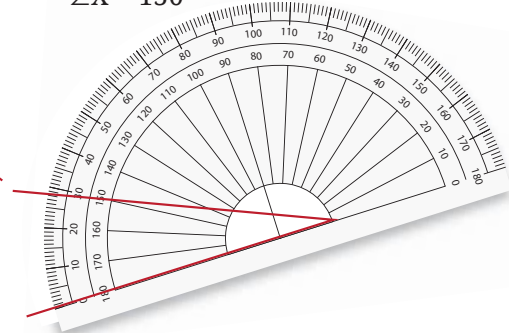

$\angle Y = 120^\circ$

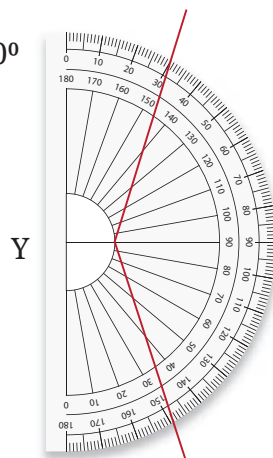

$\angle Z = 85^\circ$

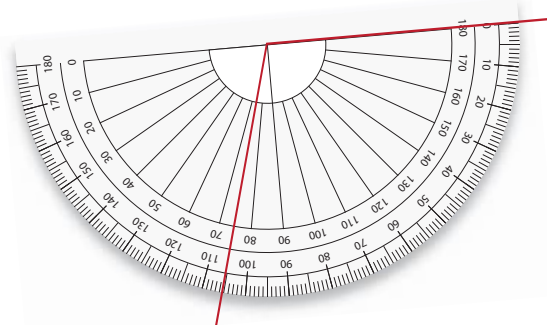
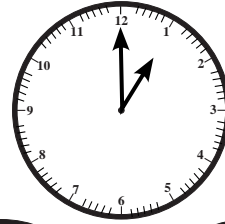

 **Figure it Out**

Where are the angles?

1. Angles in a clock:

a. The hands of a clock make different angles at different times. At 1 o'clock, the angle between the hands is 30° . Why?



b. What will be the angle at 2 o'clock? And at 4 o'clock? 6 o'clock?

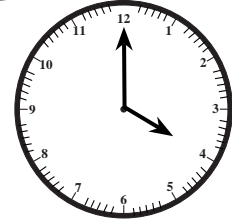
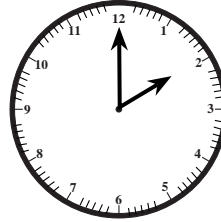

c. Explore other angles made by the hands of a clock.

2. The angle of a door:

Is it possible to express the amount by which a door is opened using an angle? What will be the vertex of the angle and what will be the arms of the angle?



3. Vidya is enjoying her time on the swing. She notices that the greater the angle with which she starts the swinging, the greater is the speed she achieves on her swing. But where is the angle? Are you able to see any angle?



4. Here is a toy with slanting slabs attached to its sides; the greater the angles or slopes of the slabs, the faster the balls roll. Can angles be used to describe the slopes of the slabs? What are the arms of each angle? Which arm is visible and which is not?
5. Observe the images below where there is an insect and its rotated version. Can angles be used to describe the amount of rotation? How? What will be the arms of the angle and the vertex?



Hint: Observe the horizontal line touching the insects.



Teacher's Note

It is important that students see the application of each mathematical concept in their daily lives. Teacher can organise some activities where students can appreciate the practical applications of angles in real-life situations, e.g., clocks, doors, swings, concepts of uphill and downhill, location of the sun, the giving of directions, etc.

2.10 Drawing Angles

Vidya wants to draw a 30° angle and name it $\angle TIN$ using a protractor.

In $\angle TIN$, I will be the vertex, IT and IN will be the arms of the angle. Keeping one arm, say IN, as the reference (base), the other arm IT should take a turn of 30° .

Step 1: We begin with the base and draw \overrightarrow{IN} :



Step 2: We will place the centre point of the protractor on I and align \overrightarrow{IN} to the 0 line.

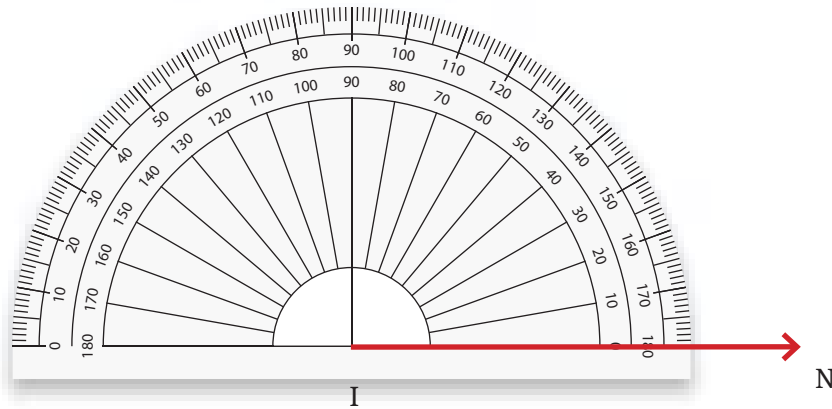

Step 3: Now, starting from 0, count your degrees (0, 10, 30) up to 30 on the protractor. Mark point T at the label 30°.

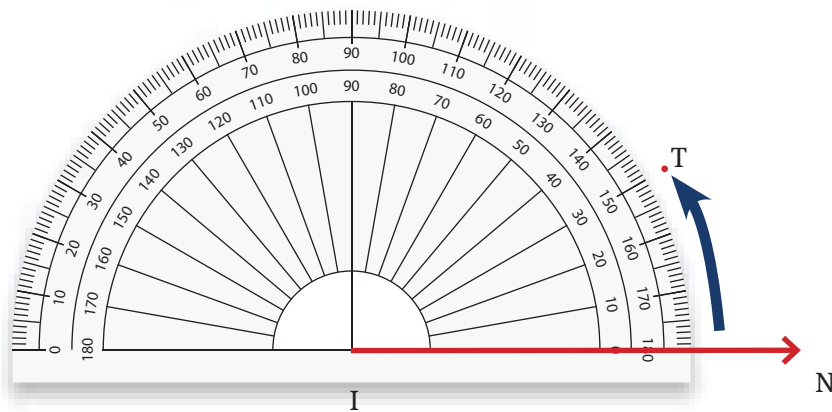

Step 4: Using a ruler join the point I and T.
 $\angle TIN = 30^\circ$ is the required angle.

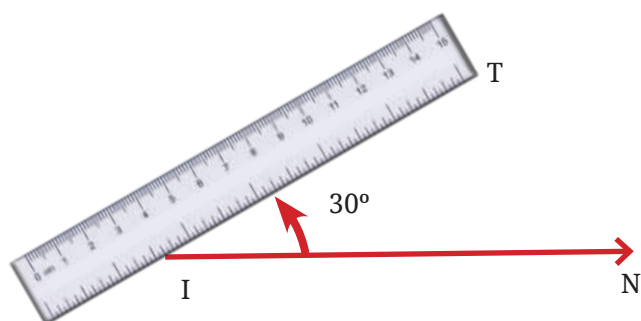

Fig. 2.22

☀ Let's Play a Game #1

This is an angle guessing game! Play this game with your classmates by making two teams, Team 1 and Team 2. Here are the instructions and rules for the game:

- **Team 1** secretly choose an angle measure, for example, 49° and makes an angle with that measure using a protractor without Team 2 being able to see it.
- **Team 2** now gets to look at the angle. They have to quickly discuss and guess the number of degrees in the angle (without using a protractor!).
- **Team 1** now demonstrates the true measure of the angle with a protractor.
- **Team 2** scores the number of points that is the absolute difference in degrees between their guess and the correct measure. For example, if Team 2 guesses 39° , then they score 10 points ($49^\circ - 39^\circ$).
- Each team gets five turns. The winner is the team with the lowest score!

☀ Let's Play a Game #2

We now change the rules of the game a bit. Play this game with your classmates by again making two teams, Team 1 and Team 2. Here are the instructions and rules:

- **Team 1** announces to all, an angle measure, e.g., 34° .
- A player from **Team 2** must draw that angle on the board without using a protractor. Other members of **Team 2** can help the player by speaking words like ‘Make it bigger!’ or ‘Make it smaller!’.
- A player from **Team 1** measures the angle with a protractor for all to see.
- **Team 2** scores the number of points that is the absolute difference in degrees between **Team 2**’s angle size and the intended angle size. For example, if player’s angle from **Team 2** is measured to be 25° , then **Team 2** scores 9 points ($34^\circ - 25^\circ$).
- Each team gets five turns. The winner is again the team with the lowest score.

Teacher’s Note

These games are important to play to build intuition about angles and their measures. Return to this game at least once or twice on different days to build practice in estimating angles. Note that these games can also be played between pairs of students.

Figure it Out

1. In Fig. 2.23, list all the angles possible. Did you find them all? Now, guess the measures of all the angles. Then, measure the angles with a protractor. Record all your numbers in a table. See how close your guesses are to the actual measures.

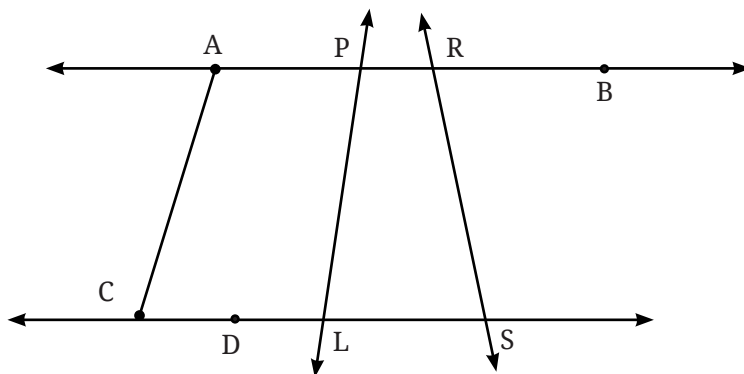
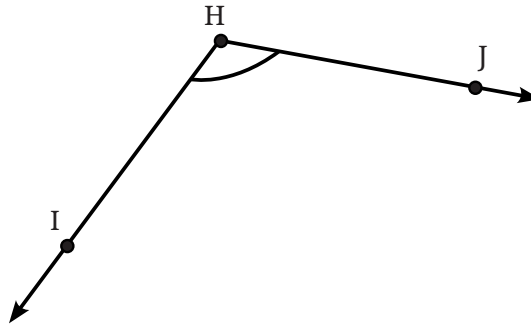

Fig. 2.23

2. Use a protractor to draw angles having the following degree measures:
 a. 110° b. 40° c. 75° d. 112° e. 134°
3. Draw an angle whose degree measure is the same as the angle given below:



Also, write down the steps you followed to draw the angle.

2.11 Types of Angles and their Measures

We have read about different types of angles in this chapter. We have seen that a straight angle is 180° and a right angle is 90° . How can other types of angles — acute and obtuse — be described in terms of their degree measures?

Acute Angle: Angles that are smaller than the right angle, i.e., less than 90° and are greater than 0° , are called **acute** angles.

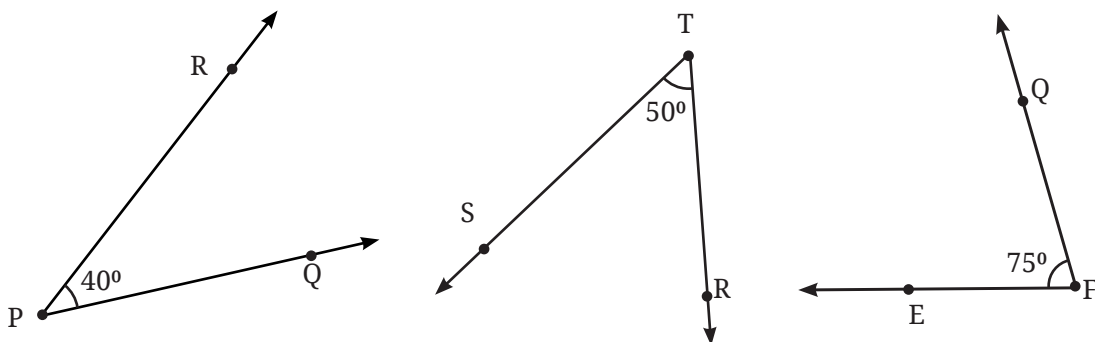

Examples of acute angles

Obtuse Angle: Angles that are greater than the right angle and less than the straight angle, i.e., greater than 90° and less than 180° , are called **obtuse** angles.

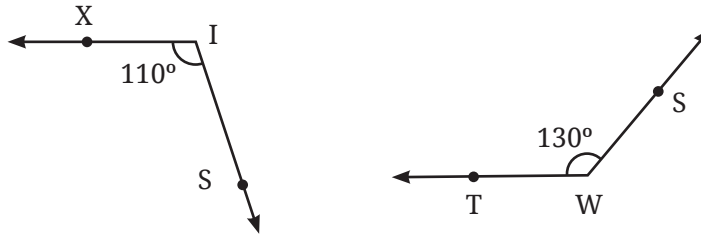

Examples of obtuse angles

Have we covered all the possible measures that an angle can take? Here is another type of angle.

Reflex angle: Angles that are greater than the straight angle and less than the whole angle, i.e., greater than 180° and less than 360° , are called **reflex** angles.

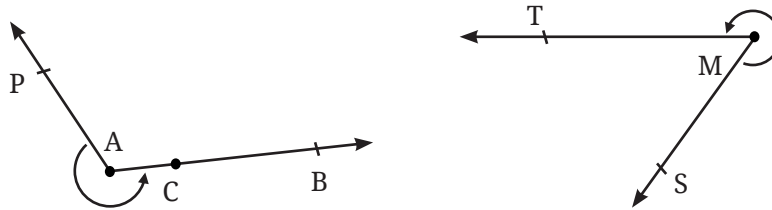

Examples of reflex angles

 **Figure it Out**

1. In each of the below grids, join A to other grid points in the figure by a straight line to get:

a. An acute angle

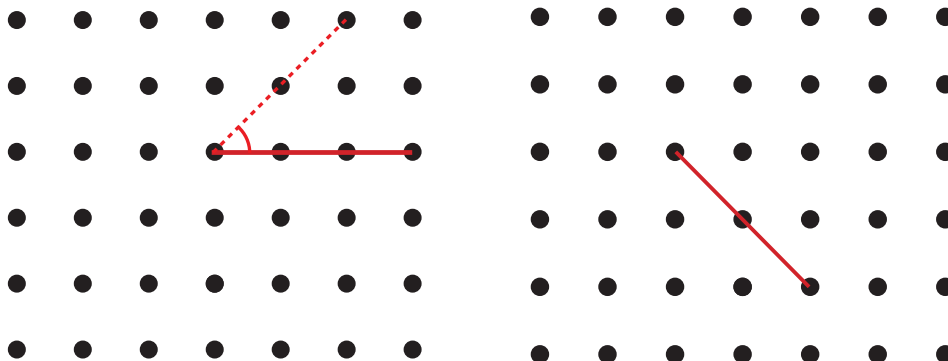

b. An obtuse angle

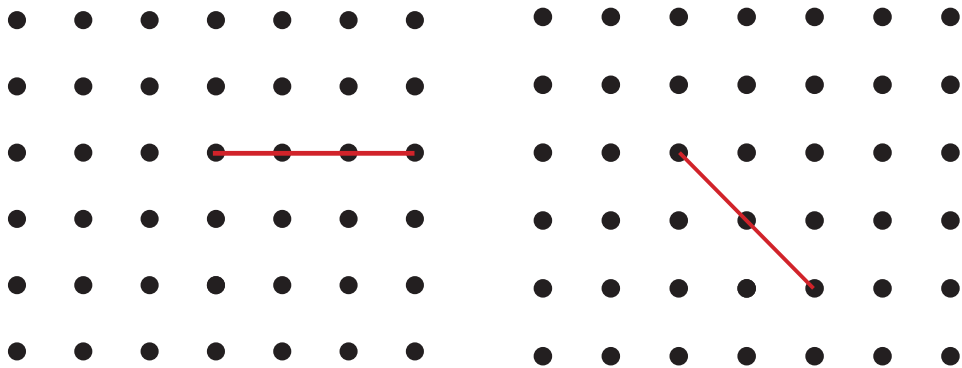

c. A reflex angle

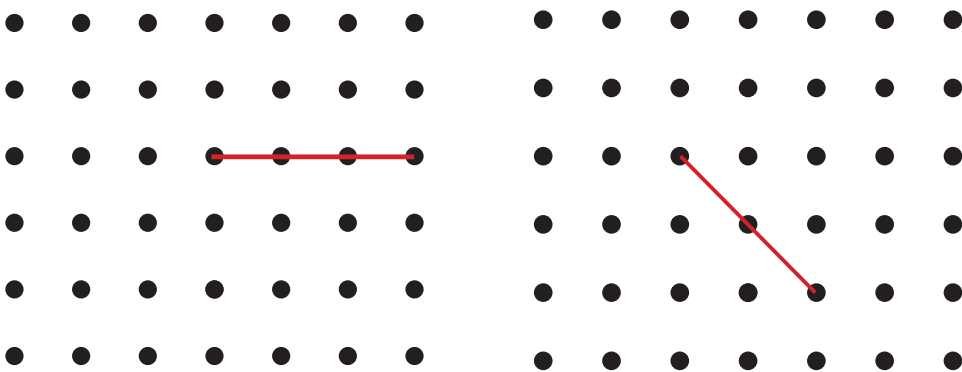

Mark the intended angles with curves to specify the angles. One has been done for you.

2. Use a protractor to find the measure of each angle. Then classify each angle as acute, obtuse, right, or reflex.

- a. $\angle PTR$ b. $\angle PTQ$ c. $\angle PTW$ d. $\angle WTP$

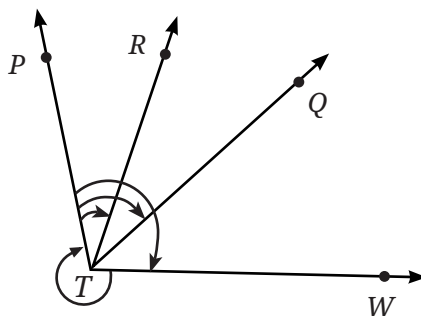

 **Let's Explore**

In this figure, $\angle TER = 80^\circ$. What is the measure of $\angle BET$? What is the measure of $\angle SET$?

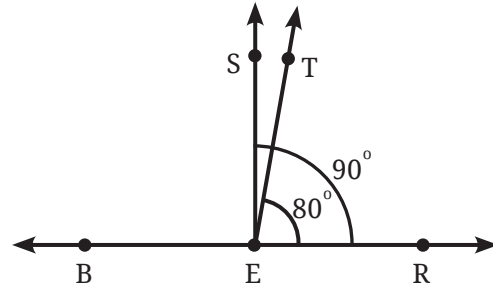

Hint: Observe that $\angle REB$ is a straight angle. Hence, the degree measure of $\angle REB = 180^\circ$ of which 80° is covered by $\angle TER$. A similar argument can be applied to find the measure of $\angle SET$.

 **Figure it Out**

1. Draw angles with the following degree measures:
 - a. 140°
 - b. 82°
 - c. 195°
 - d. 70°
 - e. 35°
2. Estimate the size of each angle and then measure it with a protractor:

a.

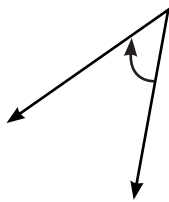

b.

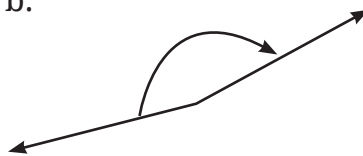

c.



d.

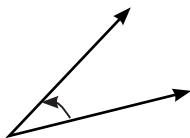

e.

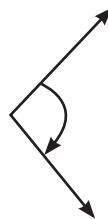

f.

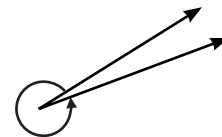

Classify these angles as acute, right, obtuse or reflex angles.

3. Make any figure with three acute angles, one right angle and two obtuse angles.
4. Draw the letter 'M' such that the angles on the sides are 40° each and the angle in the middle is 60° .
5. Draw the letter 'Y' such that the three angles formed are 150° , 60° and 150° .

6. The *Ashoka Chakra* has 24 spokes. What is the degree measure of the angle between two spokes next to each other? What is the largest acute angle formed between two spokes?



7. **Puzzle:** I am an acute angle. If you double my measure, you get an acute angle. If you triple my measure, you will get an acute angle again. If you quadruple (four times) my measure, you will get an acute angle yet again! But if you multiply my measure by 5, you will get an obtuse angle measure. What are the possibilities for my measure?

SUMMARY

- A **point** determines a location. It is denoted by a capital letter.
- A **line segment** corresponds to the shortest distance between two points. The line segment joining points S and T is denoted by \overline{ST} .
- A **line** is obtained when a line segment like \overline{ST} is extended on both sides indefinitely; it is denoted by \overleftrightarrow{ST} or sometimes by a single small letter like m .
- A **ray** is a portion of a line starting at a point D and going in one direction indefinitely. It is denoted by \overrightarrow{DP} where P is another point on the ray.
- An angle can be visualised as two rays starting from a common starting point. Two rays \overrightarrow{OP} and \overrightarrow{OM} form the angle $\angle POM$ (also called $\angle MOP$); here, O is called the **vertex** of the angle, and the rays \overrightarrow{OP} and \overrightarrow{OM} are called the **arms** of the angle.
- The size of an angle is the amount of rotation or turn needed about the vertex to rotate one ray of the angle onto the other ray of the angle.
- The sizes of angles can be measured in **degrees**. One full rotation or turn is considered as 360 degrees and denoted as 360° .
- Degree measures of angles can be measured using a **protractor**.
- Angles can be **straight** (180°), **right** (90°), **acute** (more than 0° and less than 90°), **obtuse** (more than 90° and less than 180°), and **reflex** (more than 180° and less than 360°).